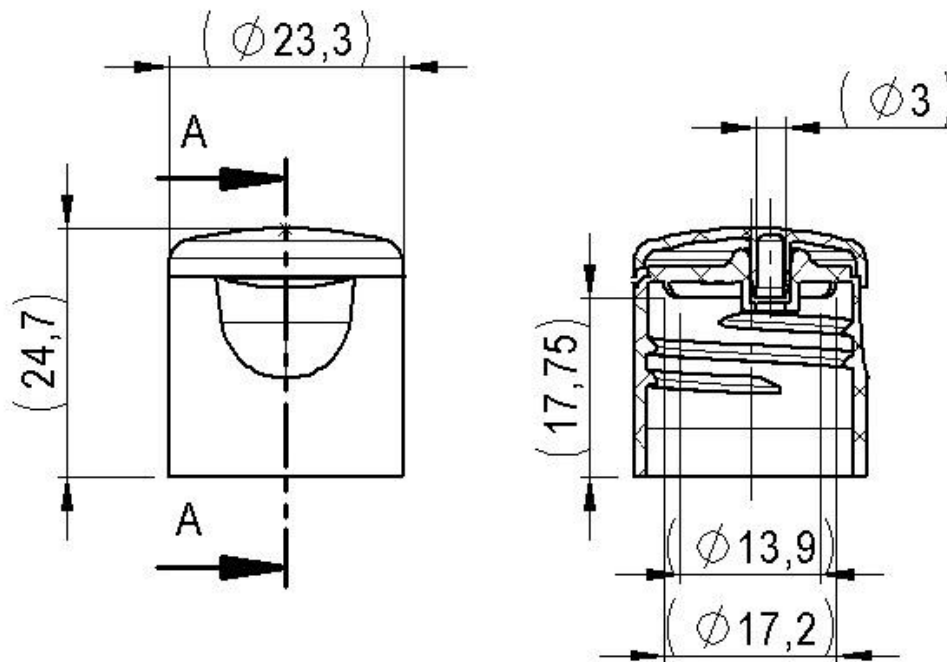
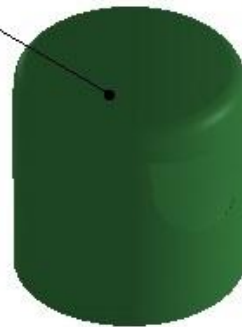
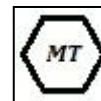

Art. cod. CE01483

**Descrizione / Description****Capsula Flip Top 20/415 tige crab****Flip-Top cap 20/415 tige crab**
 Finitura esterna lucida  
 Glossy exterior finish

 SEZIONE A-A  
 SECTION A-A
**Tabella dati tecnici / Technical data table**

Tipo filetto Thread type	Passo filetto (mm) Thread pitch (mm)	N° Principi filetto N° Thread starts	Sigillo di garanzia Tamper evident	Materiale Material	Peso (g) Weight (g)
20/415	3,175	1	No/No	PP 5	3,0 ±0,20

Il peso indicato è puramente indicativo e non valido ai fini CONAI.  
 The weight indicated is purely indicative.

## Tabella dati imballaggio-spedizione / Table packing and shipping details

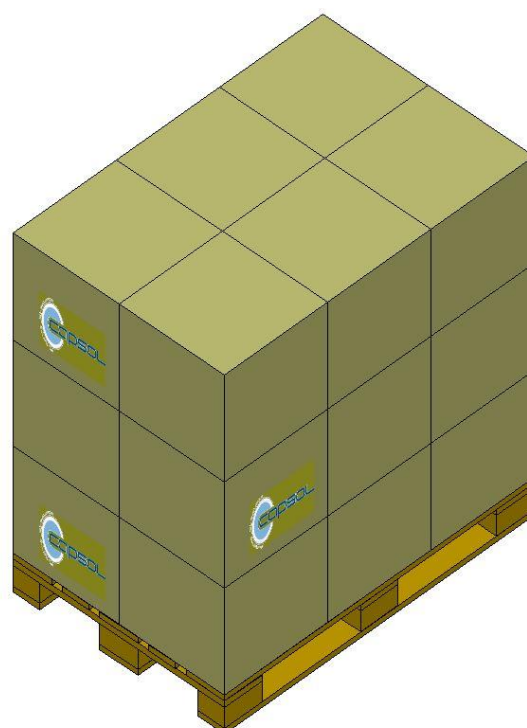
Scatola standard (cm) <i>Standard box (cm)</i>	Sacchetto <i>Bag</i>	Quantità per scatola <i>Pcs box</i>	Quantità per pallet <i>Pcs pallet</i>	Pallet (cm) <i>Pallet (cm)</i>
38x38 H:33	PE Food contact	3300	59400	120x80 H:110,5



## Stoccaggio / Storage

Conservare i prodotti nella loro confezione originale in un luogo pulito, fresco e asciutto.  
*Store the products in their original packaging in a clean, cool and dry place.*

Temperatura / Temperature : **5÷30°C**

Umidità / Humidity : **45÷75%**

Conservare i prodotti a temperatura ambiente (**20°C±5**) per **48 ore** prima dell'uso sulla macchina confezionatrice.  
*Store the products at room temperature (20°C±5) for 48H before using on packaging machine.*